

 Cambridge
IGCSE**Cambridge International Examinations**
Cambridge International General Certificate of Secondary EducationCANDIDATE
NAMECENTRE
NUMBER

--	--	--	--	--	--

CANDIDATE
NUMBER

--	--	--	--	--

MATHEMATICS**0580/41**

Paper 4 (Extended)

October/November 2016**2 hours 30 minutes**

Candidates answer on the Question Paper.

Additional Materials: Electronic calculator
 Tracing paper (optional)

Geometrical instruments

READ THESE INSTRUCTIONS FIRST

Write your Centre number, candidate number and name on all the work you hand in.

Write in dark blue or black pen.

You may use an HB pencil for any diagrams or graphs.

Do not use staples, paper clips, glue or correction fluid.

DO NOT WRITE IN ANY BARCODES.Answer **all** questions.

If working is needed for any question it must be shown below that question.

Electronic calculators should be used.

If the degree of accuracy is not specified in the question, and if the answer is not exact, give the answer to three significant figures. Give answers in degrees to one decimal place.

For π , use either your calculator value or 3.142.

At the end of the examination, fasten all your work securely together.

The number of marks is given in brackets [] at the end of each question or part question.

The total of the marks for this paper is 130.

The syllabus is approved for use in England, Wales and Northern Ireland as a Cambridge International Level 1/Level 2 Certificate.

This document consists of **19** printed pages and **1** blank page.

- 1 (a) (i) Divide \$105 in the ratio 4 : 3.

\$ and \$ [2]

- (ii) Increase \$105 by 12%.

\$ [2]

- (iii) In a sale the original price of a jacket is reduced by 16% to \$105.

Calculate the original price of the jacket.

\$ [3]

- (b) Jakob invests \$500 at a rate of 2% per year compound interest.
Claudia invests \$500 at a rate of 2.5% per year simple interest.

Calculate the difference between these two investments after 30 years.
Give your answer in dollars correct to the nearest cent.

\$ [6]

- (c) Michel invests \$ P at a rate of 3.8% per year compound interest.
After 30 years the value of this investment is \$1469.

Calculate the value of P .

$$P = \dots\dots\dots [3]$$

- (d) The population of a city increases exponentially at a rate of $x\%$ every 5 years.
In 1960 the population was 60 100.
In 2015 the population was 120 150.

Calculate the value of x .

$$x = \dots\dots\dots [3]$$

- 2 (a) 200 students record the time, t minutes, for their journey from home to school. The cumulative frequency diagram shows the results.

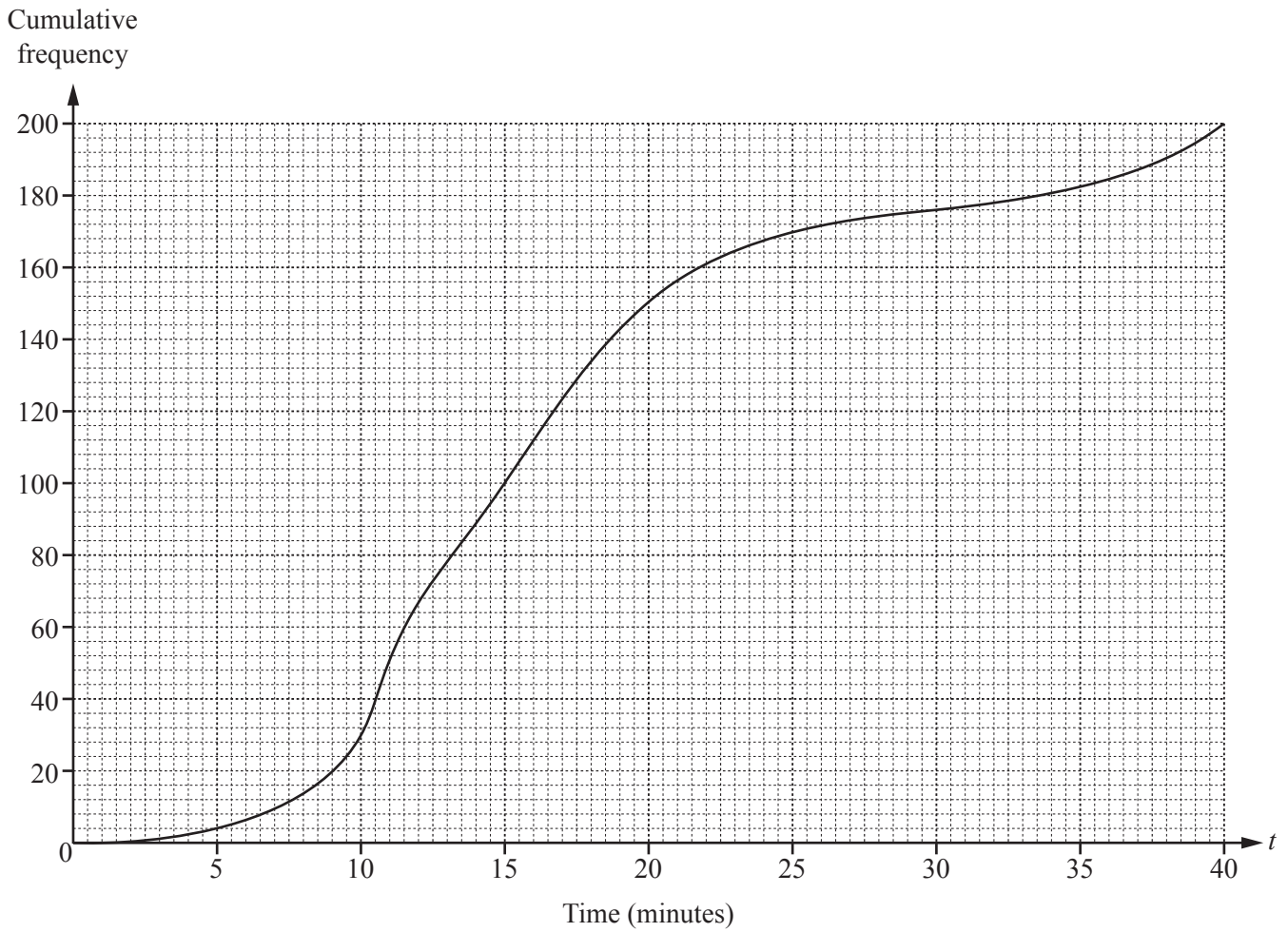

Find

- (i) the median, min [1]
- (ii) the lower quartile, min [1]
- (iii) the inter-quartile range, min [1]
- (iv) the 15th percentile, min [1]
- (v) the number of students whose journey time was more than 30 minutes. [2]

- (b) The 200 students record the time, t minutes, for their journey from school to home. The frequency table shows the results.

Time (t minutes)	$0 < t \leq 10$	$10 < t \leq 15$	$15 < t \leq 20$	$20 < t \leq 30$	$30 < t \leq 60$
Frequency	48	48	60	26	18

- (i) Calculate an estimate of the mean.

..... min [4]

- (ii) On the grid, complete the histogram to show the information in the frequency table.

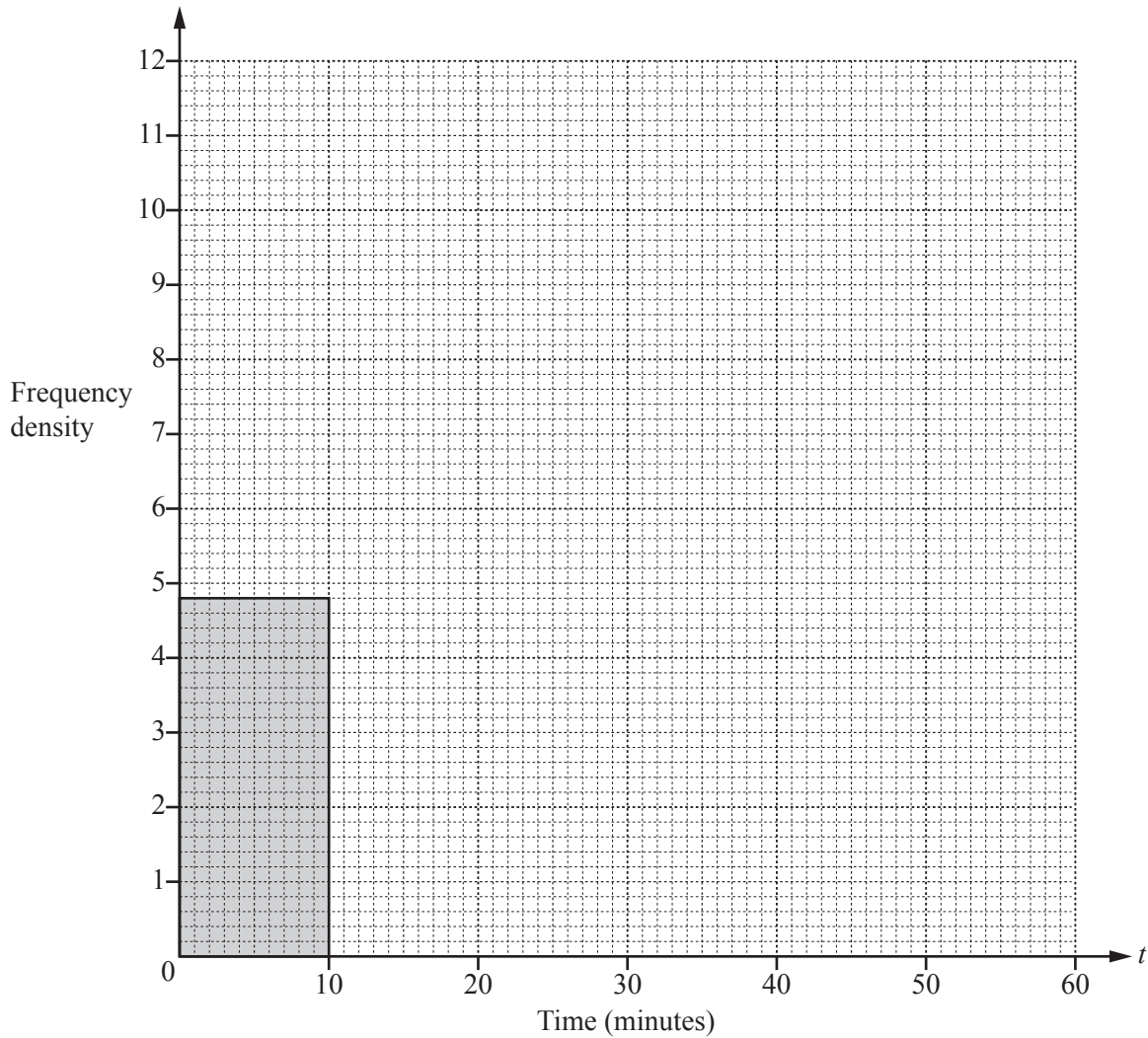

[4]

3 (a)

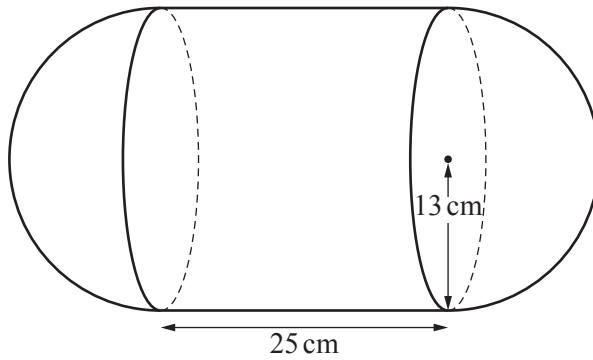

NOT TO SCALE

The diagram shows a solid made up of a cylinder and two hemispheres. The radius of the cylinder and the hemispheres is 13 cm. The length of the cylinder is 25 cm.

(i) One cubic centimetre of the solid has a mass of 2.3 g.

Calculate the mass of the solid.
Give your answer in kilograms.

[The volume, V , of a sphere with radius r is $V = \frac{4}{3}\pi r^3$.]

..... kg [4]

(ii) The surface of the solid is painted at a cost of \$4.70 per square metre.

Calculate the cost of painting the solid.

[The surface area, A , of a sphere with radius r is $A = 4\pi r^2$.]

\$..... [4]

(b)

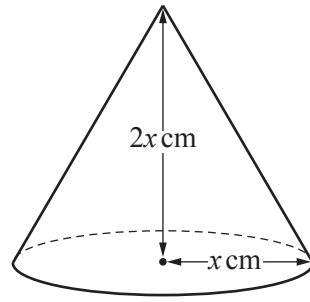

NOT TO
SCALE

The cone in the diagram has radius $x \text{ cm}$ and height $2x \text{ cm}$.
The volume of the cone is 500 cm^3 .

Find the value of x .

[The volume, V , of a cone with radius r and height h is $V = \frac{1}{3}\pi r^2 h$.]

$x = \dots\dots\dots$ [3]

(c) Two mathematically similar solids have volumes of 180 cm^3 and 360 cm^3 .
The surface area of the smaller solid is 180 cm^2 .

Calculate the surface area of the larger solid.

$\dots\dots\dots \text{cm}^2$ [3]

4 $y = 1 - \frac{2}{x^2}, x \neq 0$

(a) Complete the table.

x	-5	-4	-3	-2	-1	-0.5		0.5	1	2	3	4	5
y		0.88	0.78			-7		-7			0.78	0.88	

[3]

(b) On the grid, draw the graph of $y = 1 - \frac{2}{x^2}$ for $-5 \leq x \leq -0.5$ and $0.5 \leq x \leq 5$.

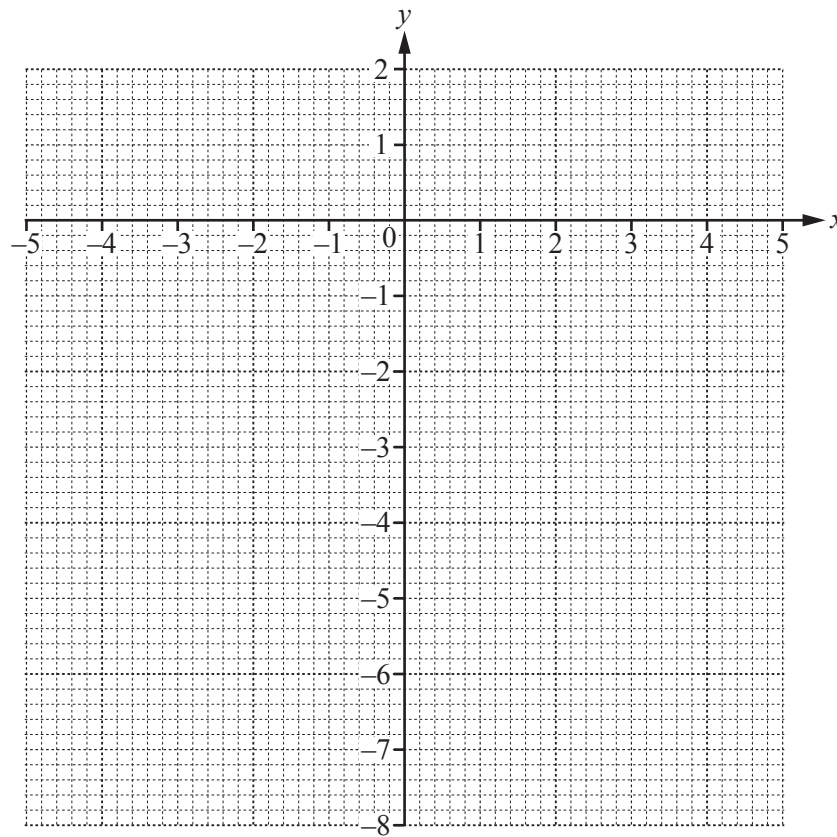

[5]

(c) (i) On the grid, draw the graph of $y = -x - 1$ for $-3 \leq x \leq 5$.

[2]

(ii) Solve the equation $1 - \frac{2}{x^2} = -x - 1$.

$x = \dots\dots\dots$ [1]

- (iii) The equation $1 - \frac{2}{x^2} = -x - 1$ can be written in the form $x^3 + px^2 + q = 0$.

Find the value of p and the value of q .

$p = \dots\dots\dots$

$q = \dots\dots\dots$ [3]

- (d) The graph of $y = 1 - \frac{2}{x^2}$ cuts the positive x -axis at A .

B is the point $(0, -2)$.

- (i) Write down the co-ordinates of A .

(..... ,) [1]

- (ii) On the grid, draw the straight line that passes through A and B . [1]

- (iii) Complete the statement.

The straight line that passes through A and B is a

at the point [2]

5

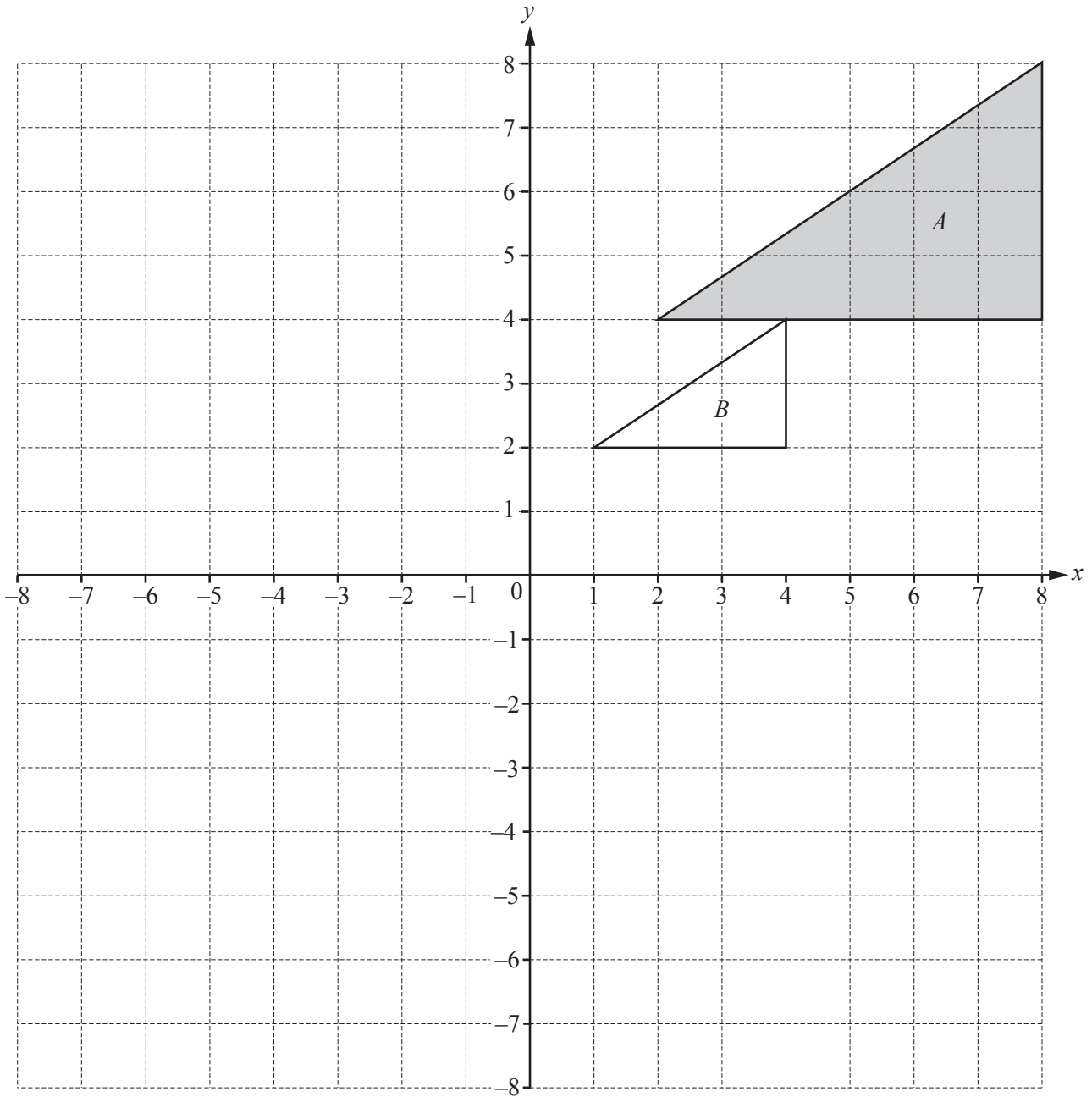

(a) $\mathbf{v} = \begin{pmatrix} -4 \\ -8 \end{pmatrix}$

(i) Draw the image of triangle *A* after the translation by vector \mathbf{v} .

[2]

(ii) Calculate $|\mathbf{v}|$.

..... [2]

- (b) (i) Describe fully the **single** transformation that maps triangle A onto triangle B .

.....

..... [3]

- (ii) Find the matrix that represents the transformation that maps triangle A onto triangle B .

$\left(\begin{array}{cc} & \\ & \end{array} \right)$ [2]

- (iii) Calculate the determinant of the matrix in **part (b)(ii)**.

..... [1]

6

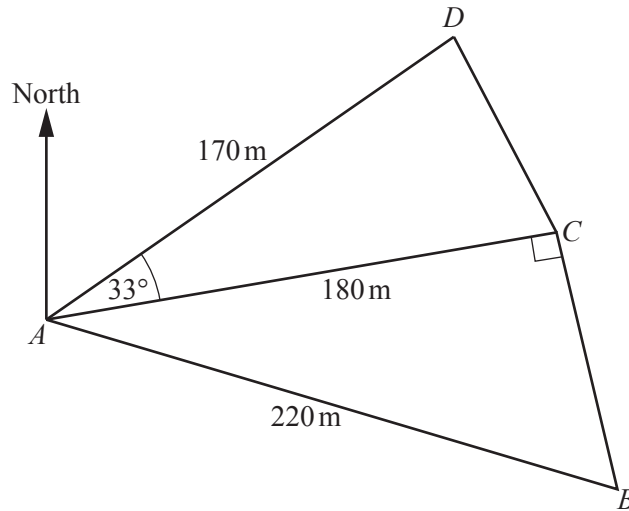

NOT TO SCALE

The diagram shows five straight footpaths in a park.
 $AB = 220$ m, $AC = 180$ m and $AD = 170$ m.
 Angle $ACB = 90^\circ$ and angle $DAC = 33^\circ$.

(a) Calculate BC .

$BC = \dots\dots\dots$ m [3]

(b) Calculate CD .

$CD = \dots\dots\dots$ m [4]

(c) Calculate the shortest distance from D to AC .

..... m [2]

(d) The bearing of D from A is 047° .

Calculate the bearing of B from A .

..... [3]

(e) Calculate the area of the quadrilateral $ABCD$.

..... m^2 [3]

- 7 A train stops at station *A* and then at station *B*.
 If the train is late at station *A*, the probability that it is late at station *B* is 0.9 .
 If the train is not late at station *A*, the probability that it is late at station *B* is 0.2 .
 The probability that the train is late at station *A* is 0.3 .

(a) Complete the tree diagram.

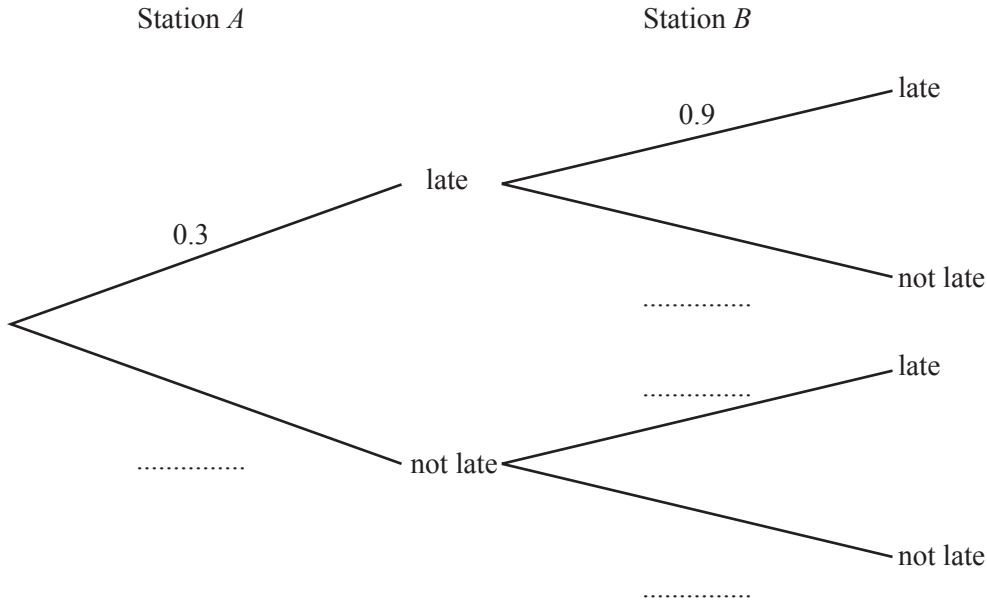

[2]

- (b) (i) Find the probability that the train is late at one or both of the stations.

..... [3]

- (ii) This train makes 250 journeys.

Find the number of journeys that the train is expected to be late at one or both of the stations.

..... [1]

- (c) The train continues to station *C*.
 The probability that it is late at all 3 stations is 0.27 .

Describe briefly what this probability shows.

.....
 [1]

8 Apples cost x cents each and oranges cost $(x + 2)$ cents each.
 Dylan spends \$3.23 on apples and \$3.23 on oranges.
 The **total** of the number of apples and the number of oranges Dylan buys is 36.

(a) Write an equation in x and show that it simplifies to $18x^2 - 287x - 323 = 0$.

[4]

(b) (i) Find the two prime factors of 323.

....., [1]

(ii) Complete the statement.

$$18x^2 - 287x - 323 = (18x \text{})(x \text{}) \quad [2]$$

(iii) Solve the equation $18x^2 - 287x - 323 = 0$.

$$x = \text{.....} \text{ or } x = \text{.....} [1]$$

(c) Find the largest number of apples Dylan can buy for \$2.

..... [1]

9 $f(x) = 2x + 1$

$g(x) = 3x - 2$

$h(x) = 3^x$

(a) Find $hf(2) - fh(1)$.

..... [3]

(b) Find $gf(x)$, giving your answer in its simplest form.

..... [2]

(c) Solve the inequality $f(x) > g(x)$.

..... [2]

(d) Solve the equation $h(x) = \frac{1}{9}$.

$x =$ [1]

(e) Find $g^{-1}(x)$.

$g^{-1}(x) =$ [2]

(f) Find $\frac{5}{f(x)} + g(x)$.

Give your answer as a single fraction.

..... [3]

(g) Solve the equation $f^{-1}(x) = 4$.

$x =$ [1]

10 (a)

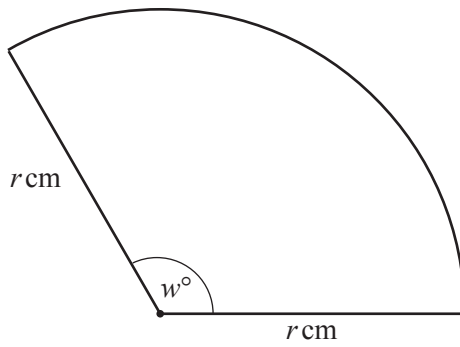

NOT TO SCALE

The area of this sector is r^2 square centimetres.

Find the value of w .

$w = \dots\dots\dots [3]$

(b)

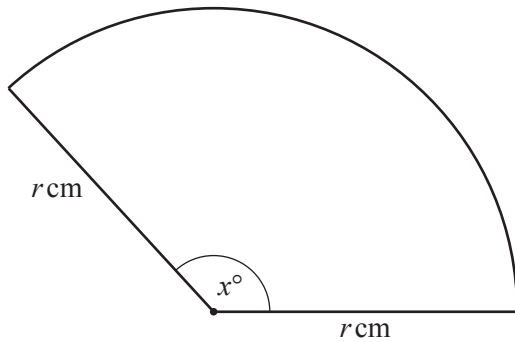

NOT TO SCALE

The perimeter of this sector is $2r + \frac{7\pi r}{10}$ centimetres.

Find the value of x .

$x = \dots\dots\dots [3]$

(c)

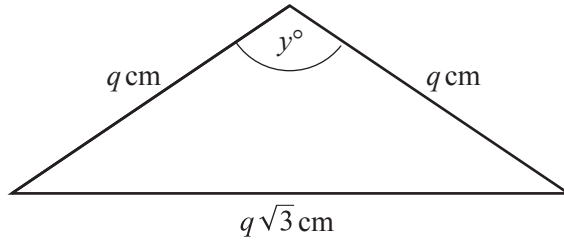
NOT TO
SCALE

The perimeter of the isosceles triangle is $2q + q\sqrt{3}$ centimetres.

Find the value of y .

$y = \dots\dots\dots$ [4]

BLANK PAGE

Permission to reproduce items where third-party owned material protected by copyright is included has been sought and cleared where possible. Every reasonable effort has been made by the publisher (UCLES) to trace copyright holders, but if any items requiring clearance have unwittingly been included, the publisher will be pleased to make amends at the earliest possible opportunity.

To avoid the issue of disclosure of answer-related information to candidates, all copyright acknowledgements are reproduced online in the Cambridge International Examinations Copyright Acknowledgements Booklet. This is produced for each series of examinations and is freely available to download at www.cie.org.uk after the live examination series.

Cambridge International Examinations is part of the Cambridge Assessment Group. Cambridge Assessment is the brand name of University of Cambridge Local Examinations Syndicate (UCLES), which is itself a department of the University of Cambridge.